

# VIZIO | Quick Setup Guide

Scan for an Easy Setup.

[vizio.com/qr/k/D4-series](https://vizio.com/qr/k/D4-series)



**Important!**

Do not touch screen.

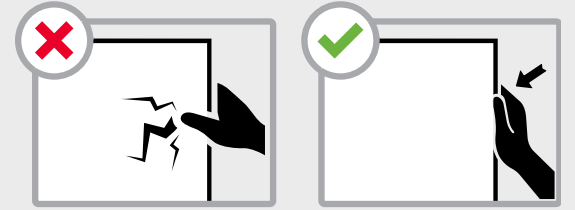

Please read the full User Manual at [support.vizio.com/s/user-manuals](https://support.vizio.com/s/user-manuals) before operating your VIZIO product and keep it for future reference. Purchase subject to full VIZIO Terms and Conditions, including **Binding Arbitration Agreement**, which may be viewed at [vizio.com/en/terms/terms-of-service](https://vizio.com/en/terms/terms-of-service). **By using this device, you accept those Terms and Conditions.**

What's Inside the Box

Smart TV | Power Cable | Remote with Batteries | TV Feet with Screws (2 or 4)

1

Place TV on a padded, flat surface that is larger than the TV, before installing feet or wallmount (not included). When the stand legs are properly connected, the legs will not shift or move.

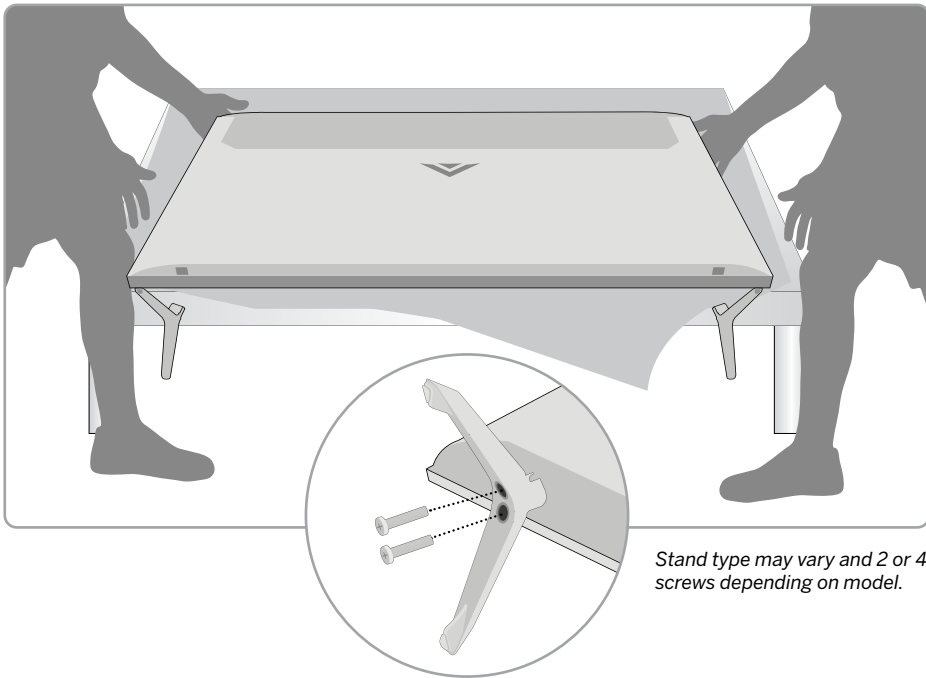

Stand type may vary and 2 or 4 screws depending on model.

2

Plug the TV power cord into a wall outlet. Connect your other devices to the TV, such as game console (not included). HDMI cable is recommended.

Adapters may be required and are not included.

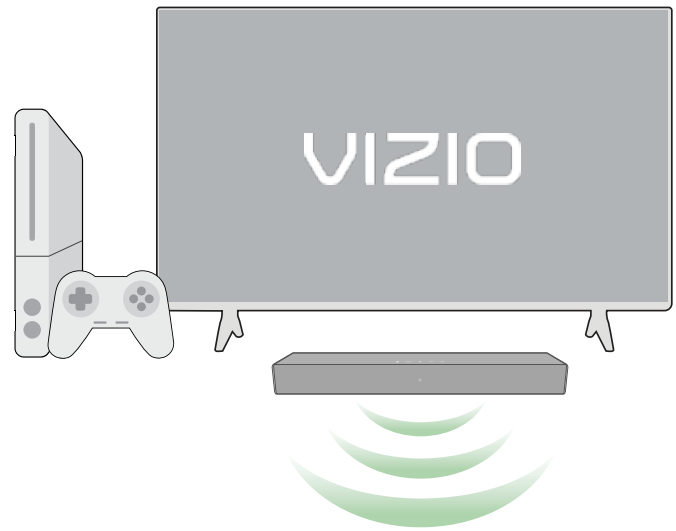

**Why HDMI?**

**Highest Quality Connection:**

Connect your devices with HDMI for the best possible picture and sound.



HDMI

**Integrated Sound Bar Control:**

When connected to select VIZIO sound bars using HDMI, audio settings may be adjusted easily via an onscreen menu.

3

Insert two AAA batteries into the remote control. Aim directly at the TV and press the power button.

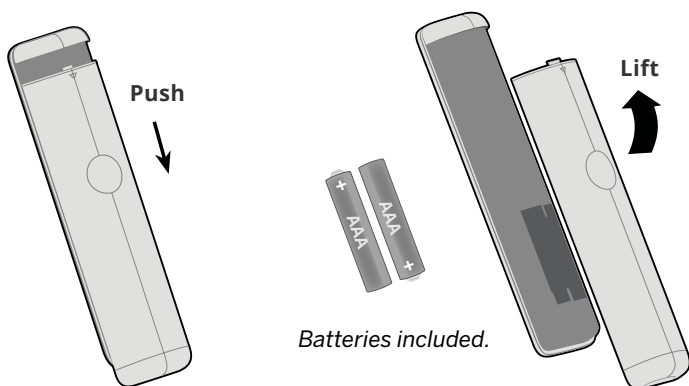

4

Follow the easy on-screen instructions to complete your setup and enjoy!

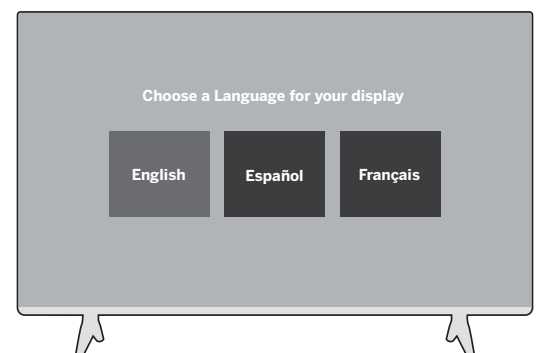

**Want the best viewing experience?**

Select a **Picture Mode setting** that best fits your room & lighting. See User Manual for more details.

### Accessibility Features

CC

Press the **CC** button to enable/disable **closed captions**. Hold down for 5 seconds to access the Accessibility Menu with features like **Talk Back** and **Zoom Mode**.

Email: [accessibility@vizio.com](mailto:accessibility@vizio.com)

Call: 1-877-698-4746 for additional support

This unit is equipped with Automated Content Recognition ("ACR") Technology which (when enabled) is able to detect commercially available content displayed on a VIZIO TV or device ("Viewing Data"). Declining Viewing Data collection will not affect the functionality of your device. To learn more, please review VIZIO's Privacy Policy at [www.vizio.com/privacy](https://www.vizio.com/privacy).

<sup>1</sup> Source: The NPD Group, Inc., U.S. Weekly Retail Tracking Service, Based on Units, Dec. 24, 2017 – Feb. 15, 2020 Combined.

Complete your home theater experience with a sound bar from **VIZIO, America's #1 Sound Bar Company**<sup>1</sup>.

[Scan here to shop our Sound Bars.](#)



**More questions?**

Get customer support help and view the User Manual here:

[support.vizio.com](https://support.vizio.com)

