

Tools Needed

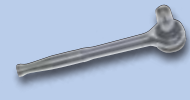

7/16" Wrench



Socket Wrench

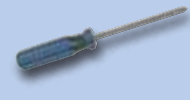

Phillips Screw Driver



Adhesive Tape

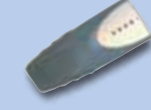

Stud Finder

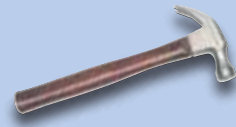

Hammer (concrete wall)



Drill with drill bits:

3/16" drill bit
(wood stud wall)

1/2" Masonry bit
(concrete wall)

Wall Mount Installation

www.tvmountingbrackets.com

Limited Warranty

Manufacturer warrants to the original purchaser of its mounting brackets for the life of the bracket, that the bracket shall be free from defects in assembly, material, or workmanship and will repair or replace, at its sole discretion, a defective bracket free of charge, provided the bracket is returned to manufacturer prepaid by purchaser. Unauthorized service or repairs by anyone other than manufacturer or a pre-approved repair facility renders this warranty void and shall release manufacturer from any further responsibility or obligation.

Manufacturer will repair or replace up to a maximum of \$10,000.00, at its option, any component (television, projector, monitor or screen) which is damaged by a manufacturer bracket's failure to perform* when that product is properly installed** for its intended use. This Lifetime Warranty is subject to the limitations and exclusions set forth herein. Manufacturer will repair or replace the damaged components (television, monitor or screen) at manufacturer option, up to an amount equal to the fair market value of the damaged equipment or the original purchase price of the equipment, whichever is less, up to the maximum amount set forth above.

Manufacturer reserves the right to inspect the damaged component, the bracket alleged to have failed, and the site where the damage occurred. All costs of shipping the manufacturer bracket and damaged component to manufacturer for inspection shall be borne solely by the purchaser. Manufacturer reserves the right to negotiate the costs of repairs. If manufacturer determines, in its sole discretion, that it is impractical to ship the damaged component or bracket to manufacturer, manufacturer may designate, in its sole discretion, a component (television, monitor or screen) repair facility to inspect and estimate the cost to repair. The cost, if any, of shipping the component to and from such repair facility and of such estimate shall be borne solely by the purchaser. Damaged components must remain available for inspection until the claim is finalized.

All above warranties are null and void if: the manufacturer's bracket in use during the occurrence is not provided to manufacturer for inspection upon request at the sole expense of the purchaser; or if manufacturer determines that the bracket has been improperly installed, altered in any way or tampered with; or if it is determined by manufacturer that the damage did not result from the Manufacturer product's failure or that in fact no occurrence took place; or the repair or replacement of the damaged equipment is covered under a manufacturer's warranty; or Manufacturer determines that the equipment was not used under normal operating conditions or in accordance with any labels or instructions. Improper installation voids the warranty. The Manufacturer warranty and assurance only protects against damage to properly connected and installed equipment where manufacturer has determined, in its sole discretion, that the damage resulted from a product failure, and does not protect against acts of God such as flood, earthquake, war, vandalism, theft, normal-use wear and tear, corrosion or abuse. Any damage caused by failure to observe instructions for installation, or product limitations specified in the product manual or product specification sheet, or mounting on unsuitable surfaces will not be covered by the Manufacturer's warranty.

The warranty described herein shall be IN LIEU OF any other warranty, express or implied, including but not limited to, any warranty of MERCHANTABILITY or FITNESS FOR A PARTICULAR PURPOSE.

In no event shall Manufacturer be liable for incidental, special, direct, indirect consequential or multiple damages such as, but not limited to, lost business or profits arising out of the sale or use of any Manufacturer products, even if advised of the possibility of damages. This warranty and insurance gives you specific legal rights, and you may also have other rights, which may vary from state to state. Some states do not allow the exclusion of limitation of incidental or consequential damage so the above limitations may not apply to you.

The warranty and insurance is valid only for the original purchaser of the product and only if the original purchaser registers the purchase on-line at www.tvmountingbrackets.com or by mailing a copy of the purchase receipt and product warranty registration card to TV Mounting Brackets Inc., 14726 Ramona Ave, Suite 201, Chino, CA 91710 within thirty (30) days of the date of purchase. All damage claims against the product must be made within fifteen (15) days from the date of the occurrence and must be accompanied by a receipt for the damaged bracket or the warranty is void. Warranty is only valid in USA and Canada. To file a warranty claim please write to us at TV Mounting Brackets Inc., 14726 Ramona Ave, Suite 201, Chino, CA 91710, within 15 days of the occurrence. Please provide to us or have the following information available:

- Manufacturer bracket part number.
- The equipment that was used with the Manufacturer bracket at the time of the occurrence.
- The component that was damaged during the occurrence and the extent of the damage.
- The date of the occurrence.
- Where you purchased the Manufacturer product.
- Date you purchased the Manufacturer product.
- Copy of the original receipt for the damaged product.

* Failure to perform in accordance with that bracket's specifications sheet or product manual
** Properly installed in accordance with that bracket's installation instruction sheet or bracket manual and only when mounted on approved surfaces.

Wood Stud Wall Installation

1 Locate Studs

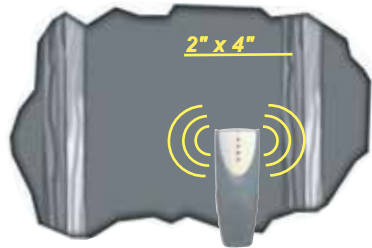

You must attach the TV wall mount to a wall that has at least 2" x 4" wood studs to avoid property damage or injury.

2 Drill Mounting Holes

- Turn poster over to the ACTUAL SIZE TEMPLATE side. Tape it to the wall so the mounting holes line up with studs. Hold the mounting plate up to the poster and use the built-in level to ensure it is level.
- Drill holes with 3/16" drill bit, 2-1/2" deep.
- Remove the poster and go to step 3.

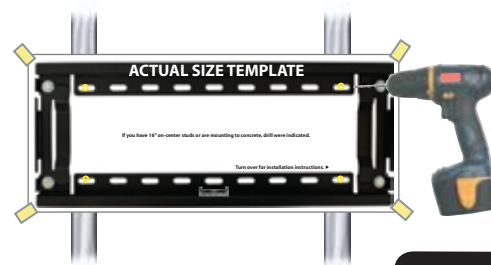

Step 3

Concrete Wall Installation

1 Drill Mounting Holes

- Turn poster over to ACTUAL SIZE TEMPLATE side. Hold the mounting plate up to the poster, and use the built-in level to ensure that it is level.
- Drill 4 holes with a 1/2" masonry bit, 2-1/2" deep where indicated.



2 Install Four Anchors

Install the provided anchors in the holes, flush with the wall, so that the hinged end faces out.

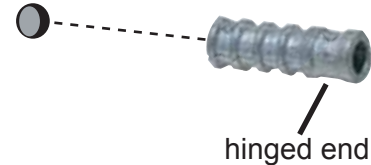

hinged end

3 Anchor Mounting Plate to Wall

Using a 7/16" wrench, attach the mounting plate to the wall with the supplied lag bolts and washers.

Use the built-in level before tightening the bolts.



4 Remove 5-degree Tilt Pieces (LPC models only)

As shipped, this mount will hang the screen tilting down 5 degrees. If you do not want the tilt, remove the 5-degree tilt pieces. If you want the tilt, leave them attached.

- Remove the bolt securing the 5-degree tilt piece to the bracket.

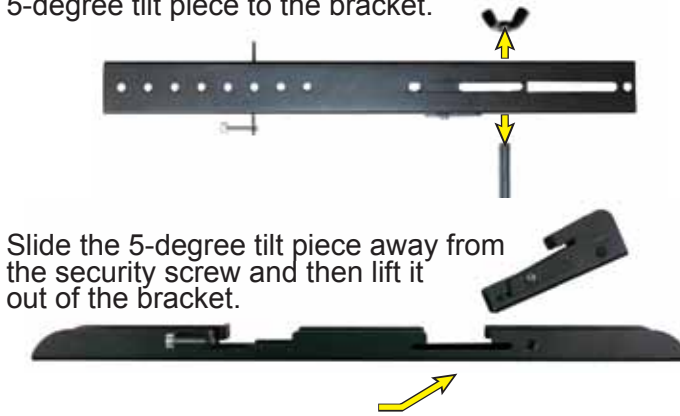

- Slide the 5-degree tilt piece away from the security screw and then lift it out of the bracket.

5 Attach Mounting Brackets

If the screws that came with your TV hold the bracket securely, use them. If not, use the provided screws.

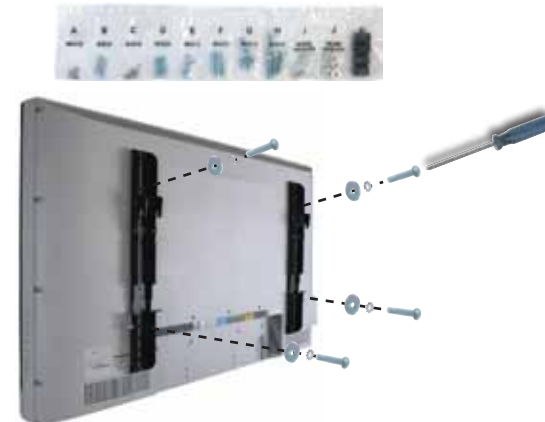

The hooks must be on the top, and the security screws must face the screen edge.

6 Hang Flat Screen

Use at least two people to lift the screen.



The screen must not exceed the maximum load weight of 100 lbs.

7 Secure the Mount

- (LPC models only) If you did not remove the 5-degree pieces, engage the lock on each bracket.

- (All mounts) Tighten the two security screws.

