

# VIZIO | Quick Setup Guide

Scan for an Easy Setup.

[vizio.com/qr/k/V5-series](https://vizio.com/qr/k/V5-series)



**Important!**

Do not touch screen.

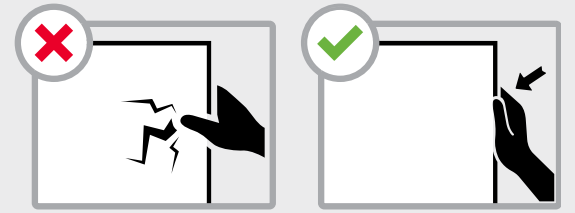

Please read the full User Manual at [support.vizio.com/s/user-manuals](https://support.vizio.com/s/user-manuals) before operating your VIZIO product and keep it for future reference. Purchase subject to full VIZIO Terms and Conditions, including **Binding Arbitration Agreement**, which may be viewed at [vizio.com/en/terms/terms-of-service](https://vizio.com/en/terms/terms-of-service). **By using this device, you accept those Terms and Conditions.**

What's Inside the Box

Smart TV | Power Cable | Voice Remote with Batteries | TV Feet with Screws (4)

**1**

Place TV on a padded, flat surface that is larger than the TV, before installing feet\* or wallmount (not included). When the stand legs are properly connected, the legs will not shift or move.

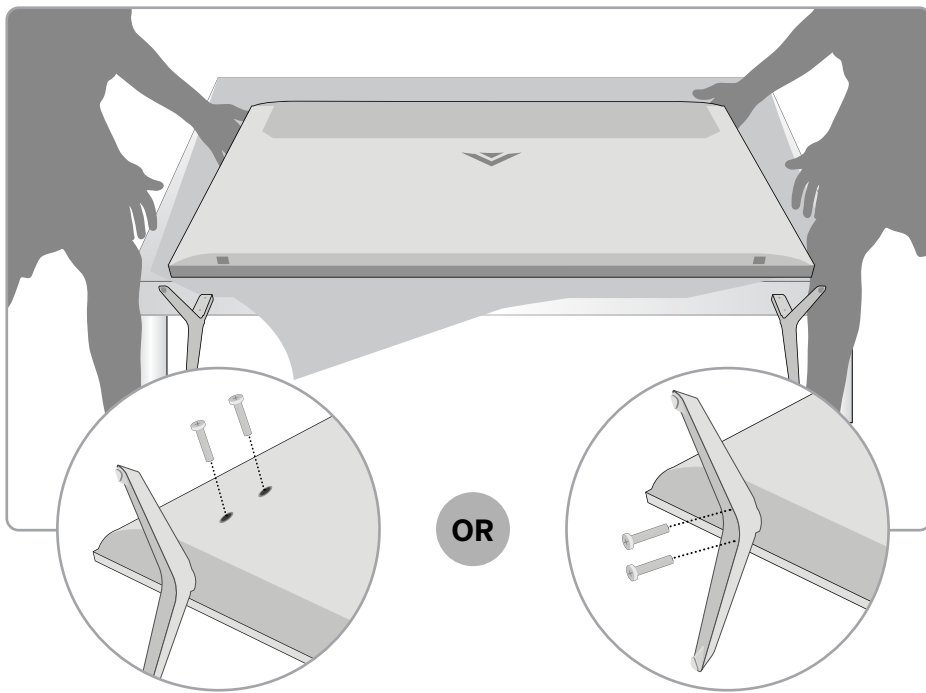

\*Stand type may vary depending on model.

**2**

Plug the TV power cord into a wall outlet. Connect your other devices to the TV, such as game console (not included). HDMI cable is recommended.

Adapters may be required and are not included.

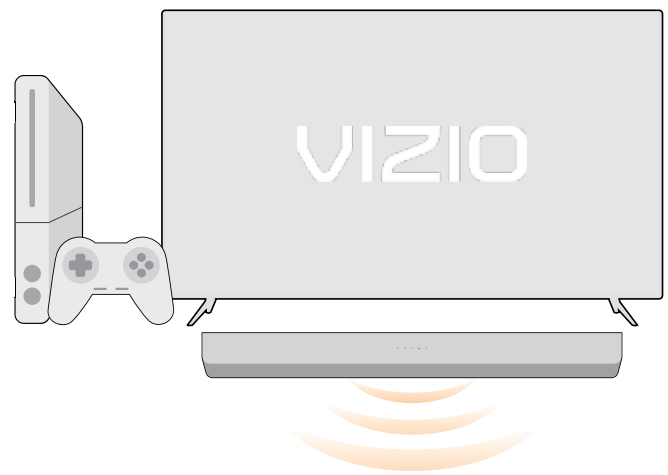

**Why HDMI?**

**Highest Quality Connection:**

Connect your devices with HDMI for the best possible picture and sound.



HDMI

**Dedicated Sound Bar Connection:** Connect a sound bar to the HDMI 1 (eARC) port on the TV (marked in green).



HDMI 1 (eARC)

**Integrated Sound Bar Control:**

When connected to select VIZIO sound bars using HDMI, audio settings may be adjusted easily via an onscreen menu.

**3**

Insert two AAA batteries into the remote control. Aim directly at the TV and press the power button.

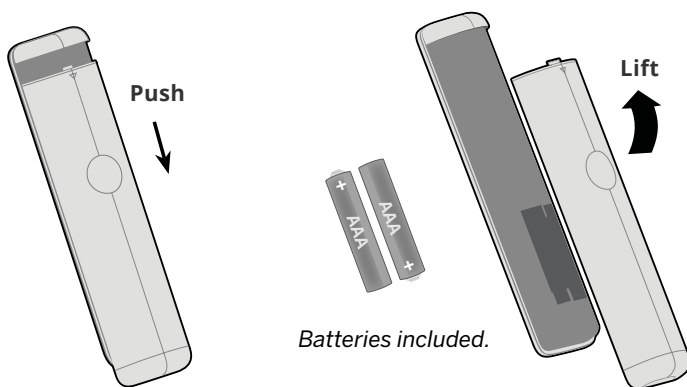

Batteries included.

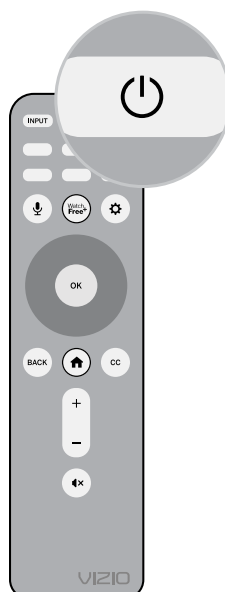

**4**

Follow the easy on-screen instructions to complete your setup and enjoy!

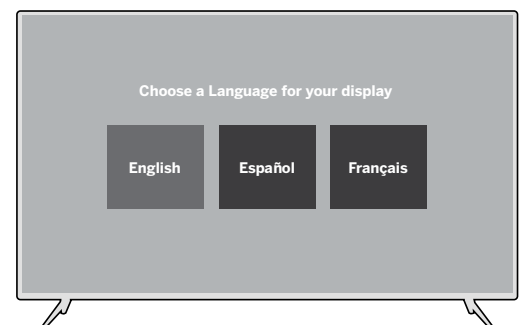

CC

**Accessibility Features**

Press the **CC** button to enable/disable **closed captions**. Hold down for 5 seconds to access the Accessibility Menu with features like **Talk Back** and **Zoom Mode**.

**Email:** [accessibility@vizio.com](mailto:accessibility@vizio.com)  
**Call:** 1-877-698-4746 for additional support



**Want the best viewing experience?**

Select a **Picture Mode setting** that best fits your room & lighting. See User Manual for more details.

This unit is equipped with Automated Content Recognition ("ACR") Technology which (when enabled) is able to detect commercially available content displayed on a VIZIO TV or device ("Viewing Data"). Declining Viewing Data collection will not affect the functionality of your device. To learn more, please review VIZIO's Privacy Policy at [www.vizio.com/privacy](https://www.vizio.com/privacy).

<sup>1</sup> Source: The NPD Group, Inc., U.S. Weekly Retail Tracking Service, Based on Units, Dec. 24, 2017 – Feb. 15, 2020 Combined.

Complete your home theater experience with a sound bar from **VIZIO, America's #1 Sound Bar Company**<sup>1</sup>.

**Scan here to shop our V-Series™ Sound Bars.**



**More questions?**

Get customer support help and view the User Manual here:

[support.vizio.com](https://support.vizio.com)

